

NOTES:

1. To be tightened according to Aprilia Tuareg 660 Workshop Manual.
2. Do not use Loctite or other thread locking compounds. Use copper grease.

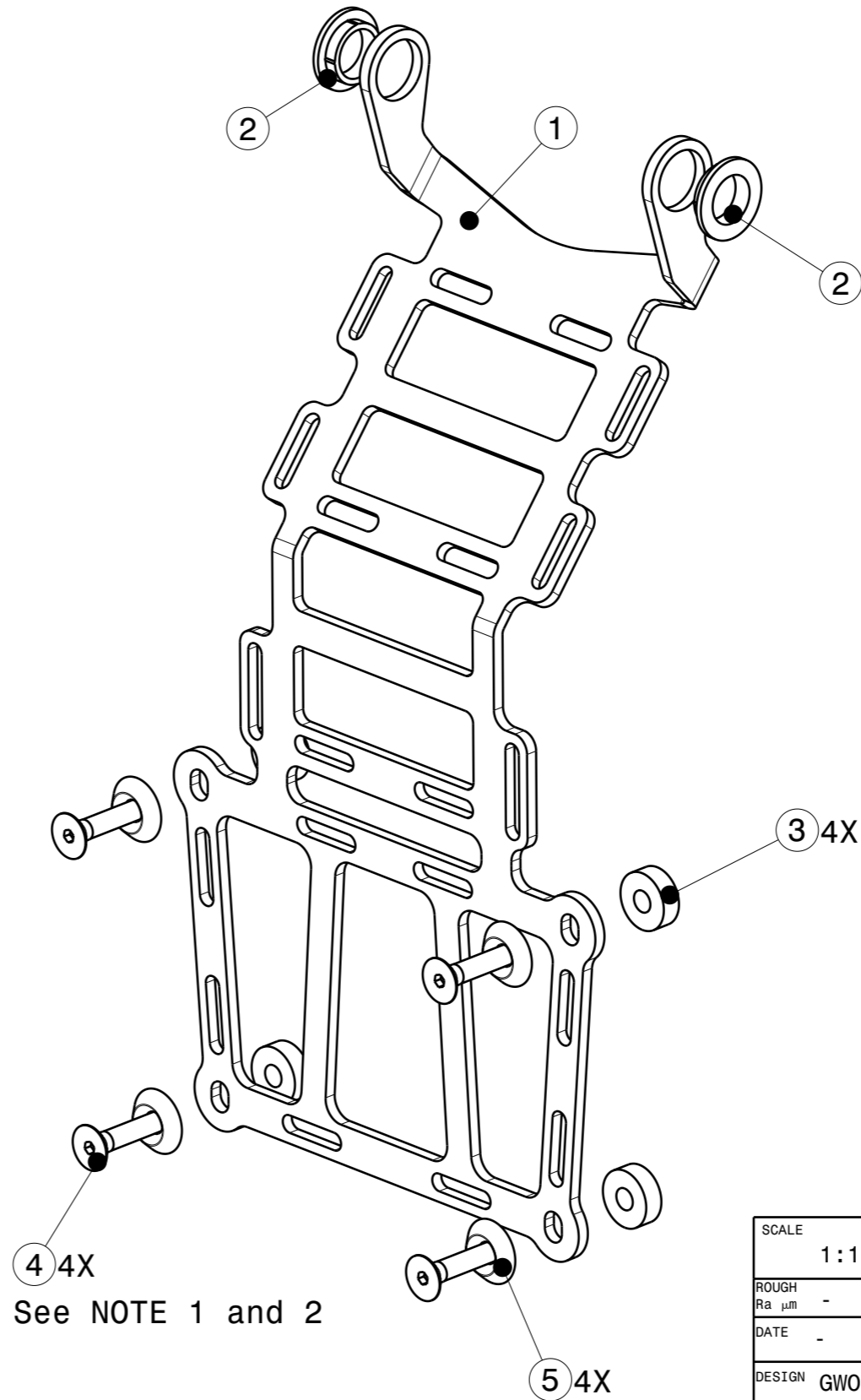
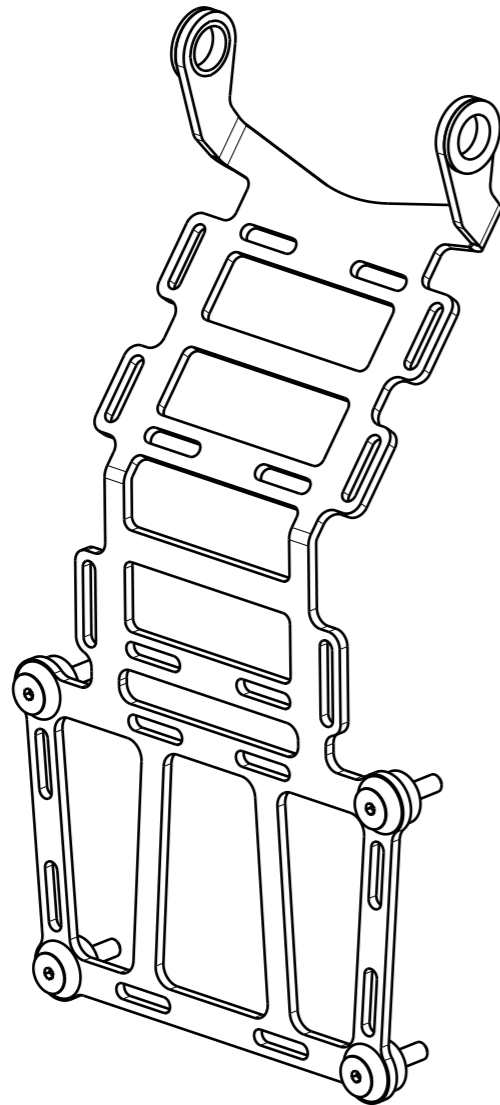

PART LIST

Description	Part Number	F/N	Qty
Tools Frame Extended	FGWX-03-A-004	1	1
Bushing 3mm	FGWX-01-D-003	2	2
Spacer Frame A	FGWX-02-A-002	3	4
Screw Csk M5x25		4	4
Csk Washer M5		5	4

SCALE 1:1		BREAK ALL EDGES (R ALT. 45°) 0.1-0.5		GWORX	
ROUGH Ra μm -		THREAD TOL. 6g/6H ISO R965/1			
DATE -		FILLET RADIOI -		DIM TOL -	
DESIGN GWORX		ANG TOL -		PROJECTION	
DRAWN GWORX		DESCRIPTION Tools Frame Extended			
MAT. -		SURF. TREATMENT -			
SIZE -		DOC.NO. FGWX-03-A		REV. - SHEET 1 OF 1	